



**Instructions for Installation 51-21001 2010 Midsize Polaris Ranger Soft Door Rear Kit
(PO-10MIDRANGER -SDK01)**

Notice: Do not smoke inside the cab or expose the enclosure to direct flames. Cab is Flammable.

1. Be sure to read these instructions thoroughly before opening and installing the cab enclosure. The installation is best done when the temperature is 70 degrees F. or warmer. This is to allow the Velcro to stick to the roll cage better, if you must install outside in the cold it will help to warm the Velcro inside at room temp. until ready to install.
2. Carefully open the carton and remove the rolled up Cab Enclosure on a large flat surface that is clean and free of dirt or other material that may soil or scratch the windows of the Cab.
3. It will help to raise the bed prior to installing the cab enclosure.

4. Check over the parts included in the carton with the parts list shown below:

<u>Velcro Hook strips Qty</u>	<u>Length</u>
2	10"
2	12"
28	3"
Snap studs	15 each (1 extra)
Cab Enclosure	1 each

5. To begin installation of the Soft Door Kit hold the door up to the frame and see where the double-sided straps will wrap around the roll cage. Take a 3" adhesive hook strip and place it on the roll cage on the inside surface of the bars at a couple of locations in the top corners to place the door where it needs to be. Then place the door up on to the frame held in place by the couple of strips. Then proceed to place the rest of the 3" adhesive strips to match up with the remaining double-sided strips sewn to the edge of the door. Photos on the next page how the system works

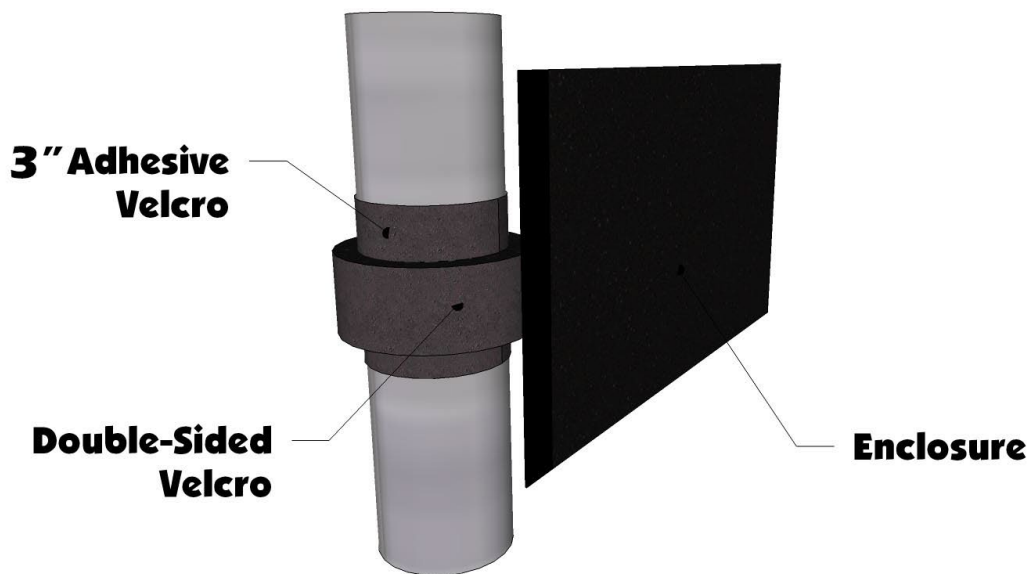
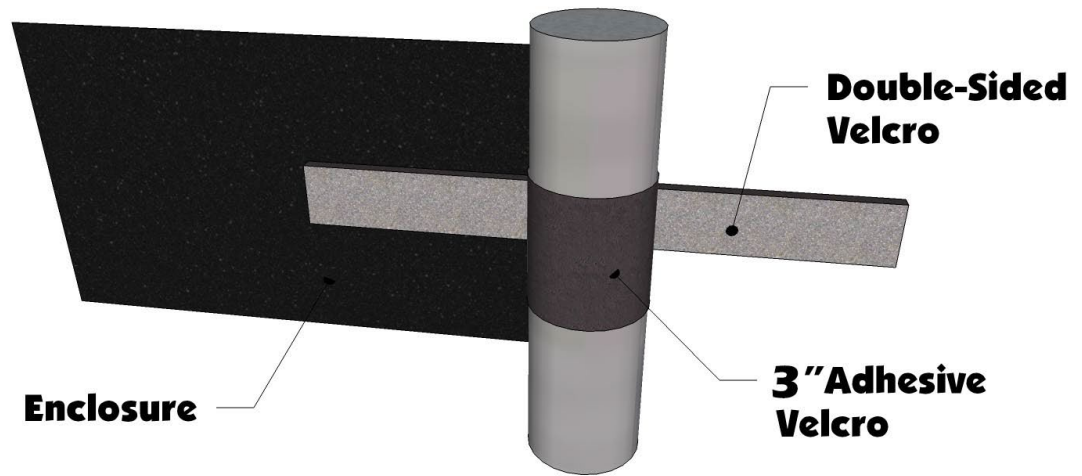
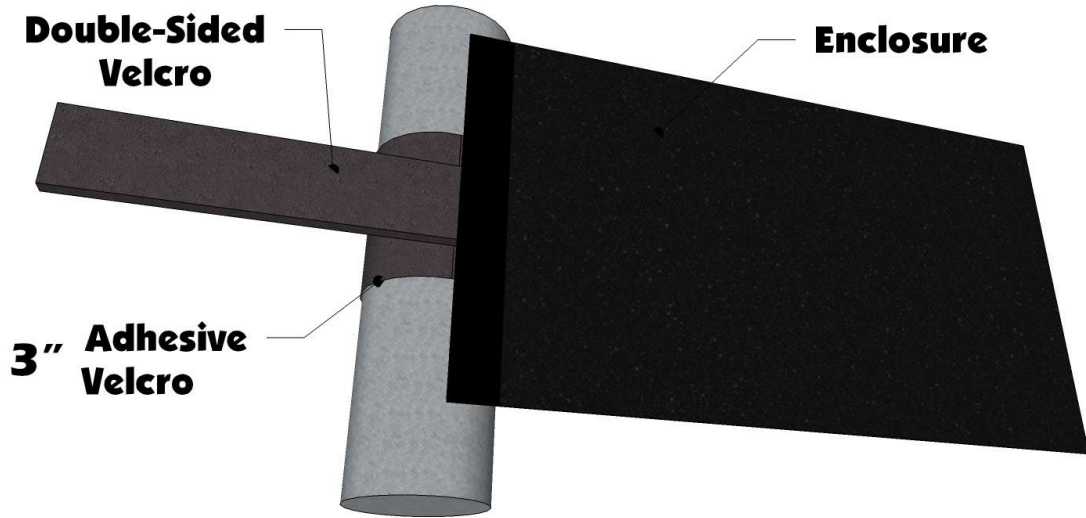

- Next take the 10" and 12" adhesive hook strips to match up with the front and rear of the door. The front gets the 10" strip on the plastic and the 12" goes on the roll cage down the back of the door. The photo below shows where the front 10" strip goes.



- Now install the snaps along the inside of the fenders to match up with the snaps on the cab enclosure and you are ready to go. The photos below will help show you where the snaps go.



Cleaning and Storage Recommendations:

1. Before removing the Cab for storage, make sure it is very clean in order to prevent scratching of the window panels. Clean with a soft rag or sponge using a mild liquid detergent soap and warm water solution. Never rub the windows with a dry cloth or rag! Let the Cab dry thoroughly before attempting to roll for storage.
2. It is important that the Cab be rolled up for storage rather than folding. Folding will cause damage to the windows!!! Carefully roll up the Cab like the way it was when it was packed at the factory. On a large, clean and flat surface, fold the doors over the rear panel first, then, interleave the top and windshield on top of the doors. Begin rolling the Cab into a roll approximately 8 inches in diameter. Put the rolled Cab back into the carton for storage at a normal room temperature. It is best not to expose the Cab to either extreme hot or cold temperatures when storing.

If you have any questions, comments, need assistance, or are missing parts, please contact us by one of the methods below.



service@seizmik.com



1-866-838-3366
between 9:00 AM and 5:00 PM EST.



www.seizmik.com/customer-support



WARNING: This product contains a chemical known to the State of California to cause cancer. For more information, go to www.P65Warnings.ca.gov.